

# SAS

- Scorrimento Angolare versione "S"  
- Angled Undercut "S" version

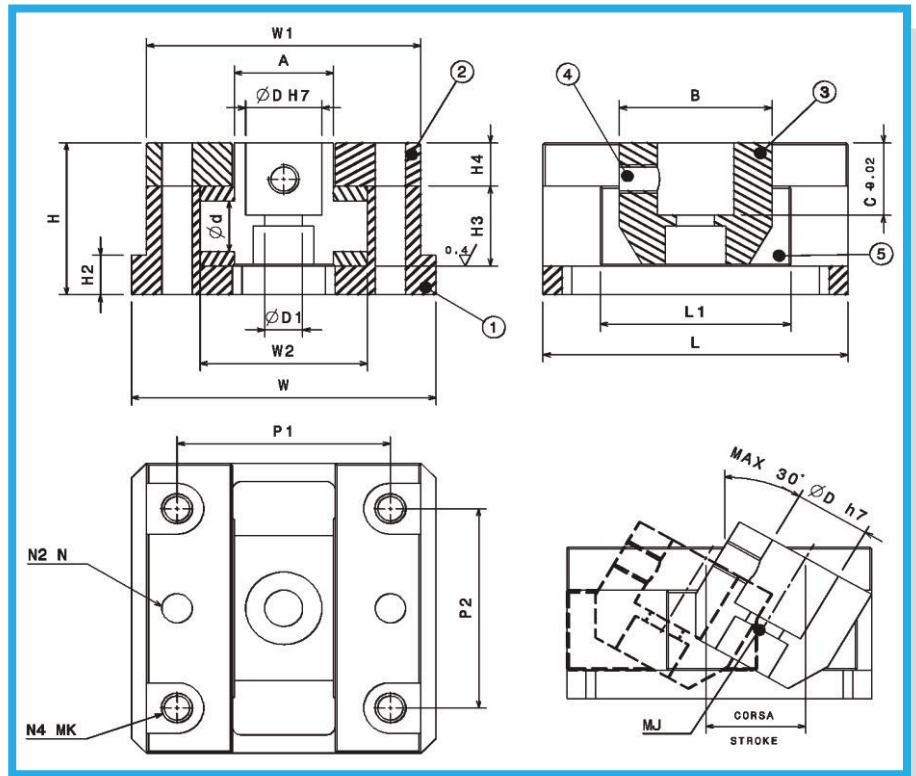
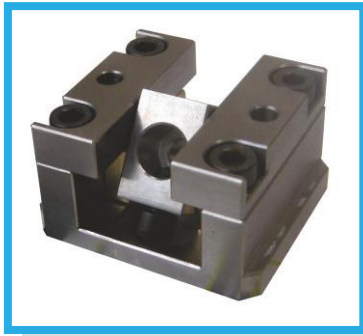

Parte Part	Note Notes
Base Base	1 pz./1 pc.
Piastrine Chiusura Lock Plate	2 pz./2 pc.
Bussola Inclinata Angled Bush	1 pz./1 pc.
Grano Grain	1 pz./1 pc.
Slitta Carrier	2 pz./

Esempio di ordinativo: Codice  
Example of purchasing order: Code

Codice Code	D	d	D1	A	B	C	MJ	H	H2	H3	H4	L	L1	W	W1	W2	P1	P2	MK	N	Corsa Stroke
SAS081120	8	7	4,5	11	20	8	M4	22	5	11	7	32	20	33	30	19	24	20	M3	3	10
SAS101525	10	7	5,5	15	25	10	M5	27	5	15	8	45	25	45	40	25	32	30	M4	4	18
SAS121725	12	10	7	17	25	12	M6	32	7	16	10	50	30	57	51	31	39	35	M6	6	20
SAS162230	16	12	9	22	30	16	M8	36	8	20	10	65	40	65	58	38	46	40	M6	6	25
SAS202640	20	14	11	26	40	20	M10	42	11	22	12	80	50	80	72	44	56	55	M8	8	30
SAS253245	25	16	14	32	45	25	M12	50	15	26	15	90	55	93	85	52	66	65	M10	10	35
SAS303850	30	18	14	38	50	30	M12	55	15	30	15	100	60	101	93	60	74	70	M10	10	40
SAS354560	35	20	14	45	60	35	M12	62	15	34	18	120	75	120	110	70	85	80	M12	10	45
SAS405570	40	25	18	55	70	40	M16	70	15	44	18	135	85	130	120	80	95	90	M12	10	50
SAS456080	45	30	18	60	80	45	M16	80	15	50	20	150	95	140	130	90	105	110	M12	10	55