

CAM

- Camme di Espulsione
- Ejector Cam

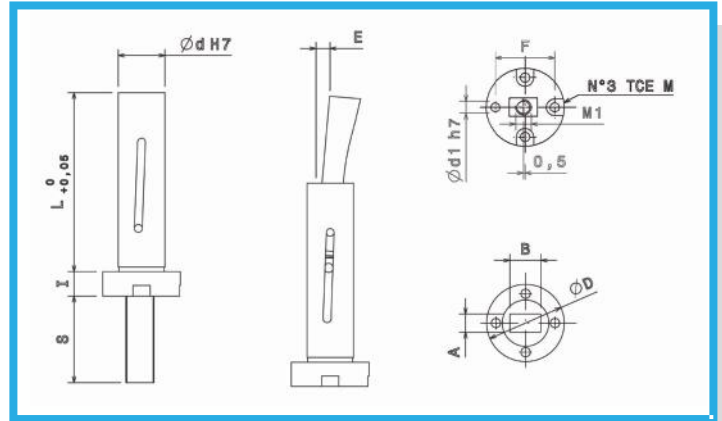

Esempio di ordinativo: Codice
Example of purchasing order: Code

Part.	Materiale Material	Trattamento Treatment	Rivestimento Coating
Pinza -Clamp	1.2343/44	Tempra 50/52 Hrc Hardening 50/52 Hrc	Wonder
Asta -Pin	1.2343/44	Tempra 50/52 Hrc Hardening 50/52 Hrc	
Bussola -Bush	1.2842	Tempra 54/56 Hrc Hardening 54/56 Hrc	

Codice Code	A	B	D	d	d1	L	I	S	E	M	M1	F
CAM04	4	7	22	12	3	48	8	25	4	M3	M3	16
CAM05	5	7	22	12	3	48	8	25	4	M3	M3	16
CAM06	6	10	25	15	3	58	8	28	4,8	M3	M5	19
CAM08	8	10	26	16	3	58	8	28	4,8	M3	M5	20
CAM10	10	12	29	19	3	58	8	30	5,4	M3	M5	23
CAM12	12	12	34	21	4	66	10	35	5,8	M4	M6	26
CAM14	14	15	38	24	4	66	10	35	5,8	M4	M6	30

- Esecuzione Camme Speciali
- Special Cam Execution

Parte Part	Materiale Material	Trattamento Treatment	Rivestimento Coating
Pinza -Clamp	1.2343/44	Tempra 50/52 Hrc Hardening 50/52 Hrc	Wonder
Asta -Pin	1.2343/44	Tempra 50/52 Hrc Hardening 50/52 Hrc	
Bussola -Bush	1.2842	Tempra 54/56 Hrc Hardening 54/56 Hrc	

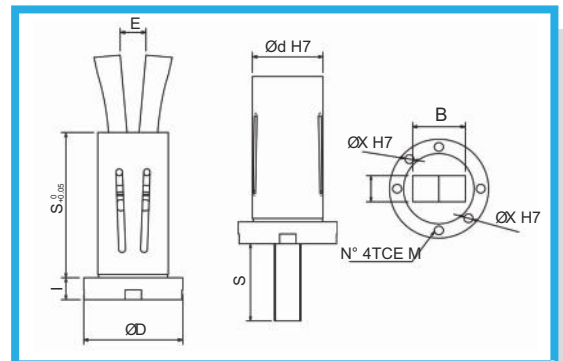

Esempio di ordinativo: Codice + Caratteristiche tecniche del particolare da realizzare
Example of purchasing order: Code + Technical data of particular execution

Codice Code	A	B	D	d	L	I	S	E
CAM - S								